

CAM TUBE SYSTEM

DATA SHEET
LIT NO: 49441-235
DATE: Spring 2001



Cam Tube System standard on INTRAAX®

Hendrickson leads the world in trailer air-ride suspension technology. We lead by demonstrating a steadfast commitment to serving customers' needs and continual advancement of our world class products with innovative solutions.

We reinforce that position with the addition of the Cam Tube System as standard equipment on all INTRAAX® models beginning in the spring of 2001. Fleets and owner operators asked for longer life brake components, reduced maintenance costs and increased uptime for their trailers. Hendrickson delivers with the first standard Cam Tube System for trailer brake systems.

Similar to proven tube concepts used on Prime Movers, the Cam Tube System, patent pending, fits standard and HXS® (Hendrickson Extended Service) brakes. By locking out contamination, this self-contained, extended service cam tube stretches the life of camshafts and bushings to rival long-life brake linings and hub assemblies.

It features a single, easily accessible grease fitting, and with a new spider design, trims even more weight from what is already the industry's lightest suspension, axle and brake system. The perfect alignment of the two bushings contained within the Cam Tube System further improves the industry-leading responsiveness of INTRAAX® brakes.

For The Road Ahead

 **HENDRICKSON**

Cam Tube System

Longer life for brake S-cam components

Hendrickson's Cam Tube System increases uptime for your trailers by eliminating the weakest link in the S-cam maintenance chain. It also reduces weight and improves brake performance.

The Cam Tube System fits all INTRAAX® brake systems:
16.5-by-07-inch and 8 5/8-inch sizes, both standard and HXS.

Benefits

- Extends S-cam bushing and journal life
- Reduces S-cam friction
- Improves brake responsiveness
- Trims brake hardware by more than 2.7kg on axle
- Ideal for off-highway and harsh-duty applications
- Maximises trailer investment

Features

- Steel tube encases both camshaft support bushings and steels
 - Plated for corrosion resistance
- Eliminates inner seals
 - Cuts contaminant access points by 50 percent
- Long-life seals and bushings
 - Double-lipped, oil-type seals
 - Rubber seal material contains ozone inhibitor
 - Glass-reinforced nylon bushings
- Increases grease volume by seven times
 - For better lubrication and protection from contaminants
- Easy access to grease fitting
- Modular cartridge design for ease of replacement
 - No welding required

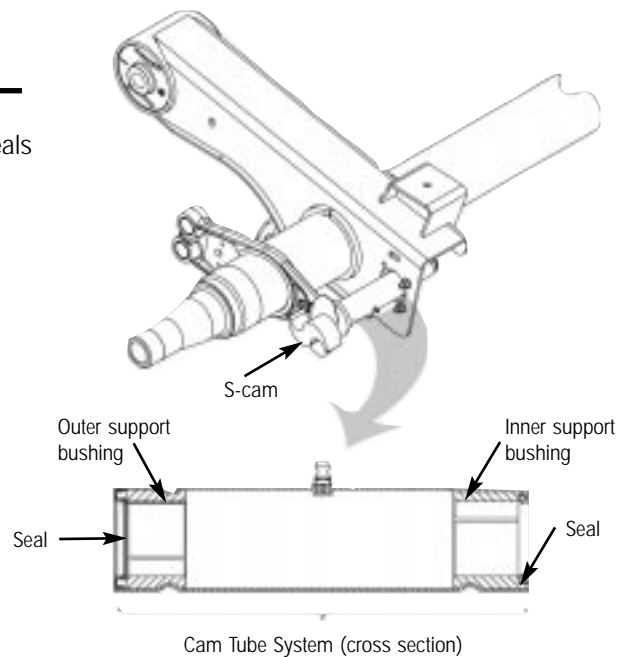
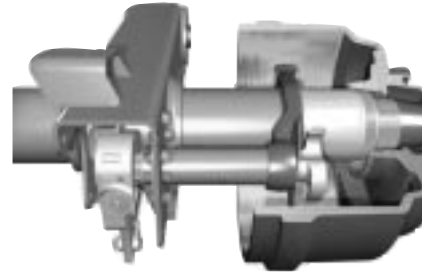

For additional information, call your dealer or Hendrickson on +61 39767 3400
or visit our web site at www.hendrickson.com.au



Hendrickson Asia Pacific
5 Abbots Road Dandenong
Victoria 3175
Ph: 61 39767 3400
Fax: 61 39767 3499

Information contained in this literature was accurate at the time of publication. Product changes may have been made after the copyright date that are not reflected.
HEN 2447 5/01 P/N 49441-235

www.hendrickson.com.au

The Boler Company.
Copyright ©2001
Hendrickson Trailer
Suspension Systems
All Rights Reserved