

TECHNICAL PROCEDURE

INTRAAX®/VANTRAAX®

SUBJECT: Weld-On ABS Bracket
Field Installation Procedure

LIT NO: L778

DATE: February 2002

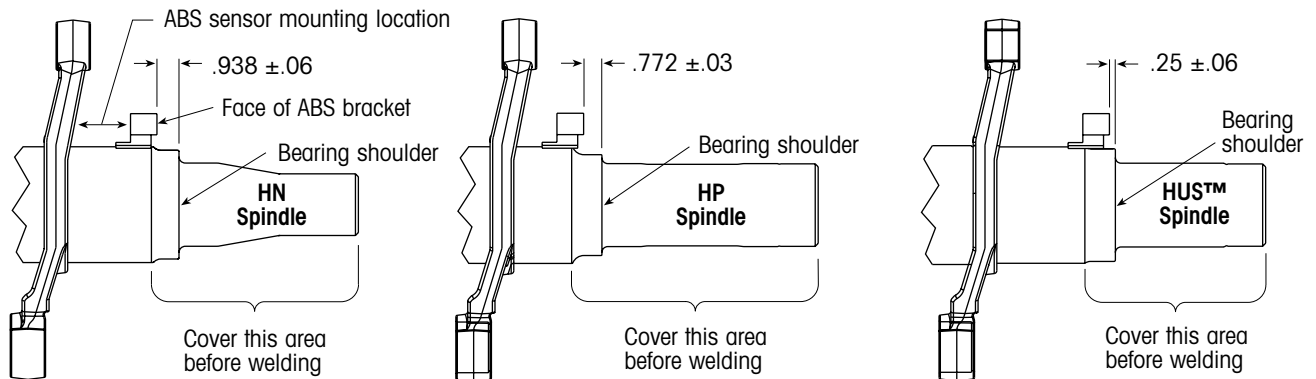

All dimensions in inches

Figure 1. Positioning the ABS bracket along the length of the axle

INSTALLING THE ABS BRACKET

NOTE: This kit (part number S-27117) is intended for installation on Hendrickson INTRAAX® and VANTRAAX® suspensions only. It is not to be installed on any other make, model or type of suspension.

1. Remove the tire/wheel assembly, brake drum, brake shoes and hub. If necessary, refer to Hendrickson publication L496, *Wheel-End Maintenance Procedures*, for complete removal details.
2. Prepare the mating surfaces for welding. The mounting area on the axle and the ABS bracket must be free of moisture, dirt, scale, paint and grease. The axle and the ABS bracket must also have a minimum temperature of 60°F (16°C).
3. To position the ABS bracket along the length of the axle, measure back (inboard) from the bearing shoulder to the face of the ABS bracket the distance indicated in figure 1.

4. To position the ABS bracket around the outside diameter of the axle, align the center of the ABS bracket hole with the center of the slot in the brake spider. Refer to figure 2.

IMPORTANT: The ABS bracket hole must be aligned with the slot in the brake spider. If off

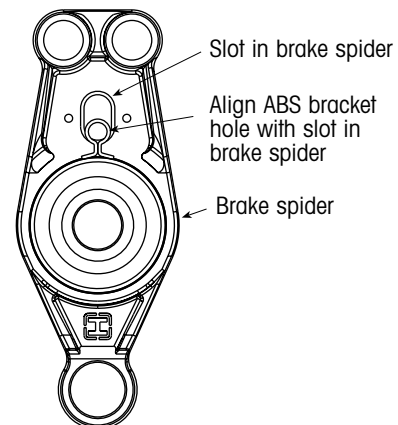

Figure 2. Aligning the ABS bracket with the brake spider slot

For The Road Ahead

HENDRICKSON

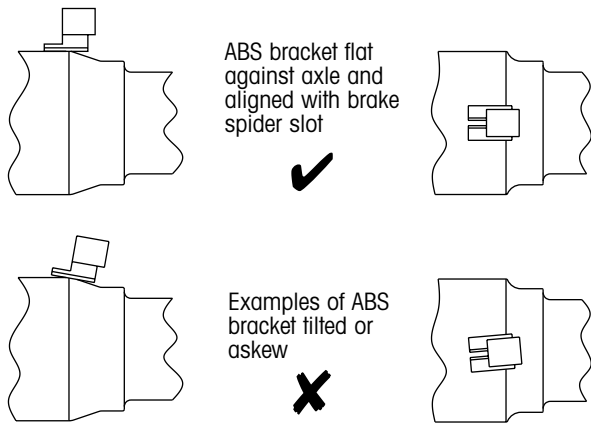

Figure 3. Properly positioning the ABS bracket

center, the ABS sensor may not clear the brake spider during installation.

- Temporarily clamp the bracket in place. Make sure the ABS bracket is flat against the axle and aligned with the slot in the brake spider. The ABS bracket must not be tilted or askew (figure 3).

- Verify that the ABS bracket is in the proper location. Insert an ABS sensor into the bracket to ensure adequate clearance with the brake spider and the hub.
- When ABS bracket location and sensor clearance are verified, weld the ABS bracket to the axle with a 1/8-inch (3mm) fillet weld. Refer to figure 4 for weld placement.

Only a properly trained and certified welder should perform the welding. Follow all applicable safety rules and regulations for welding, including but not limited to, wearing proper eye protection and other personal protective equipment, working in a well ventilated area and keeping all flammable and combustible materials out of the work area. Refer to Hendrickson publication L496, *Wheel-End Maintenance Procedures*, for additional safety information.

IMPORTANT: Before welding, cover the entire spindle area (as shown in figure 1) to avoid weld splatter damage.

- When cool, remove the clamp, prime and paint.

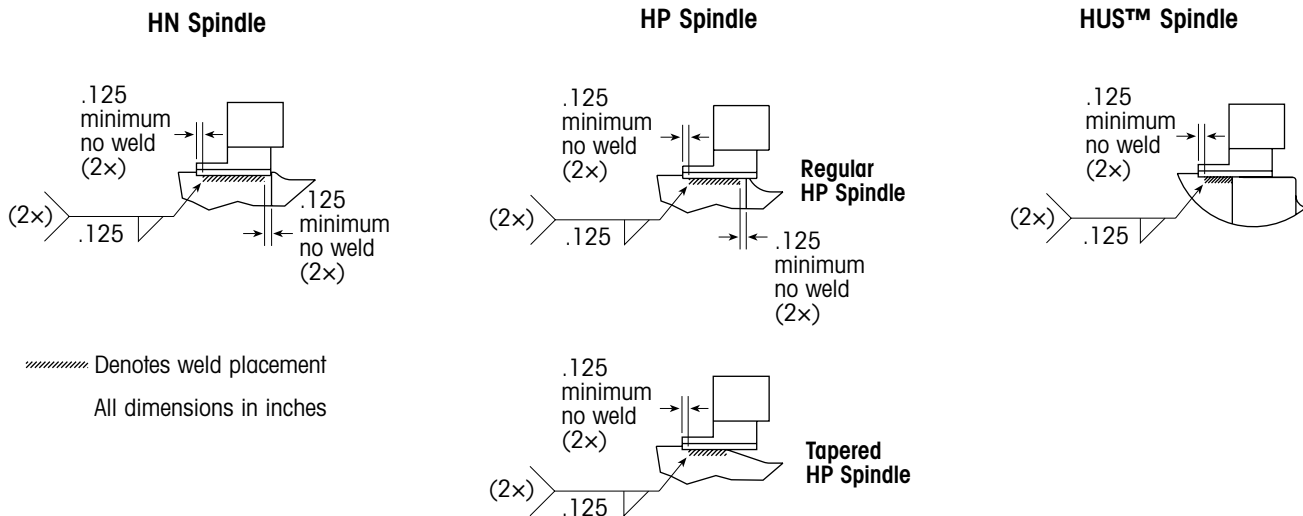

Figure 4. Welding details