

H CAM TUBE SYSTEM

DATA SHEET

LIT NO: L749

DATE: November 2000



Cam Tube System standard on INTRAAX® and VANTRAAX®

Hendrickson leads the world in trailer air-ride suspension technology. We lead by demonstrating a steadfast commitment to serving customers' needs and continual advancement of our world class products with innovative solutions.

We reinforce that position with the addition of the Cam Tube System as standard equipment on all INTRAAX® and VANTRAAX® models beginning in the spring of 2001. Fleets and owner operators asked for longer life brake components, reduced maintenance costs and increased uptime for their trailers. Hendrickson delivers with the first standard Cam Tube System for trailer brake systems.

Similar to proven tube concepts used on tractors, the Cam Tube System, patent pending, fits standard and HXS® (Hendrickson Extended Service) brakes. By locking out contamination, this self-contained, extended service cam tube stretches the life of camshafts and bushings to rival long-life brake linings and hub assemblies.

It features a single, easily accessible grease fitting, and with a new spider design, trims even more weight from what is already the industry's lightest suspension, axle and brake system. The perfect alignment of the two bushings contained within the Cam Tube System further improves the industry-leading responsiveness of INTRAAX and VANTRAAX brakes.

For The Road Ahead

H HENDRICKSON

Cam Tube System

Longer life for brake S-cam components

Hendrickson's Cam Tube System increases uptime for your trailers by eliminating the weakest link in the S-cam maintenance chain. It also reduces weight and improves brake performance.

The Cam Tube System fits all INTRAAX and VANTRAAX brake systems: 16.5-by-7-inch and 8 5/8-inch sizes, both standard and HXS.

Benefits

- Extends S-cam bushing and journal life
- Reduces S-cam friction
- Improves brake responsiveness
- Trims brake hardware by more than six pounds an axle
- Ideal for off-highway and harsh-duty applications
- Maximizes trailer investment

Features

- Steel tube encases both camshaft support bushings and seals
 - Plated for corrosion resistance
- Eliminates inner seals
 - Cuts contaminant access points by 50 percent
- Long-life seals and bushings
 - Double-lipped, oil-type seals
 - Rubber seal material contains ozone inhibitor
 - Glass-reinforced nylon bushings
- Increases grease volume by seven times
 - For better lubrication and protection from contaminants
- Easy access to grease fitting
- Modular cartridge design for ease of replacement
 - No welding required

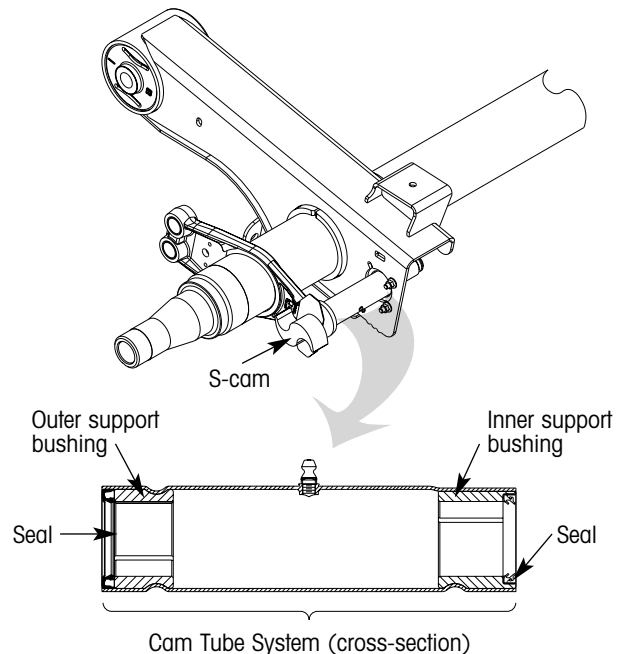
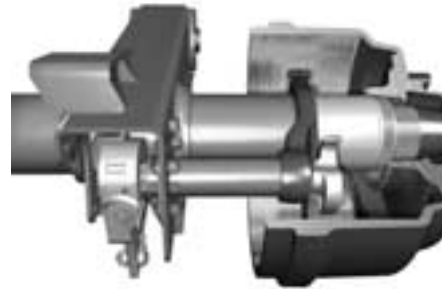

For more technical information, reference Bulletin B105

For additional information, call your dealer or Hendrickson toll free at 866-RIDEAIR (866-743-3247) or visit our web site at www.hendrickson-intl.com.

Trailer Suspension Systems
2070 Industrial Place SE
Canton, OH 44707-2600 USA
866.RIDEAIR (866.743.3247)
330.489.0045
Fax 800.696.4416



Trailer Suspension Systems
250 Chrysler Drive, Unit #3
Brampton, ON L6S 6B6 Canada
905.789.1030
Fax 905.789.1033

The Boler Company
Copyright © 2000
All Rights Reserved