

TECHNICAL PROCEDURE

HT250US SUSPENSIONS

SUBJECT: Shock Mount Replacement
Procedures

LIT NO: L725A (Supersedes AM12 Rev A and
L619)

DATE: December 1999

Replace the lower shock bolt with bolt replacement kit (S-24024).

IMPORTANT: For the parts included in the bolt replacement kit, refer to the parts list below.

LOWER SHOCK MOUNT BOLT REPLACEMENT UNDAMAGED THREAD

1. If the thread is undamaged, assemble the lower shock mount with the parts in the unshaded rows of the parts list.
2. Tighten the hex-head bolt (SA-10200-6) to 210-235 ft-lbs (285-319 N•m) of torque.

DAMAGED THREAD

IMPORTANT: If the nut for the lower shock mount is missing, contact Hendrickson Technical Service for assistance. Technical Service can be reached at (330)456-7288 Monday through Friday 8 a.m. to 5 p.m. Eastern Time.

1. Loosen the upper shock bolt and rotate the lower portion of the shock away from the mounting hole.
2. Remove the lower shock mounting threads within the suspension beam by drilling it out with a 3/4-inch drill bit.

BOLT REPLACEMENT KIT P/N S-24024 (PER SHOCK)		
PART NUMBER	PART DESCRIPTION	QUANTITY
B-24058-2	3/4"-10 x 6 1/2" Lower Shock Mount Shear-Type Bolt	1
SA-8900-3	3/4"-10 Lock Nut	2
A-22577	Hardened Flat Washers	2
A-23645	Shock Spacer Assembly	1
SA-1000-47	3/4" x 3 1/2" Upper Shock Mount Bolt	1
L619	HT250US Suspension Shock Mount Replacement Procedure	1
SA-10200-6	3/4"-10 x 5 3/4" Lower Shock Mount Bolt	1

3. Insert the new torque-prevailing nut (SA-8900-3) through the rear of the suspension beam and position it over the newly drilled $\frac{3}{4}$ -inch hole.
4. Insert the shear-type, hex-head bolt (B-24058-2) through the flat washer, shock, flat washer, spacer and $\frac{3}{4}$ -inch hole (see illustration below). Thread the bolt into the nut.
5. Hold the torque-prevailing nut with a $1\frac{1}{8}$ -inch wrench.
6. Use an E-20 $\frac{3}{4}$ -inch drive socket to tighten the shock bolt until the shear head feature separates between 210 and 235 ft-lbs of torque.
7. Visually check all components to ensure fasteners are tight.

UPPER SHOCK MOUNT BOLT REPLACEMENT

IMPORTANT: This replacement procedure is optional, unless the upper shock mount bolt requires replacement.

1. Remove the existing upper shock mount bolt.
2. Insert the $3\frac{1}{2}$ -inch shock bolt (P/N SA-1000-47) through the shock.
3. Thread the lock nut onto the upper shock mount bolt.
4. Hold the nut with $1\frac{1}{8}$ -inch wrench and tighten bolt to 210-235 ft-lbs. (285-319 N•m).

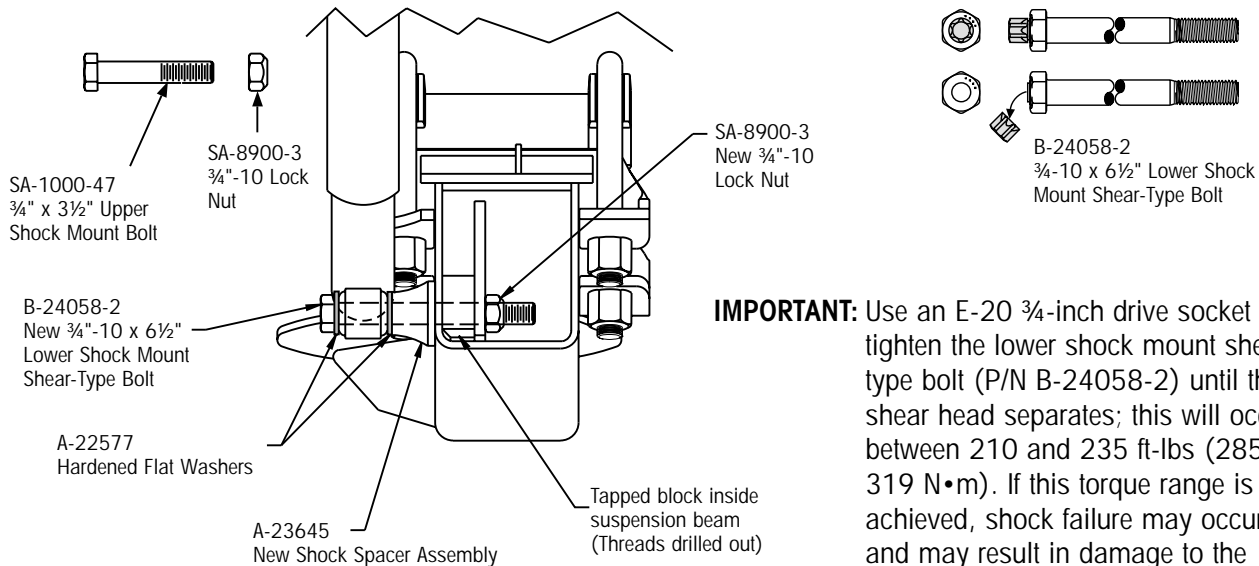

IMPORTANT: Use an E-20 $\frac{3}{4}$ -inch drive socket to tighten the lower shock mount shear-type bolt (P/N B-24058-2) until the shear head separates; this will occur between 210 and 235 ft-lbs (285 to 319 N•m). If this torque range is not achieved, shock failure may occur and may result in damage to the suspension and/or its components.