

# TECHNICAL BULLETIN

## HT230 TRAILER AIR SUSPENSION CL-100A, CL-101A, CL-102A CENTRE LIFT CONFIGURATION

**No:** TRAILER AUS-018  
**Subject:** *Product Information*  
**Date:** December 2001 **Revision:** A

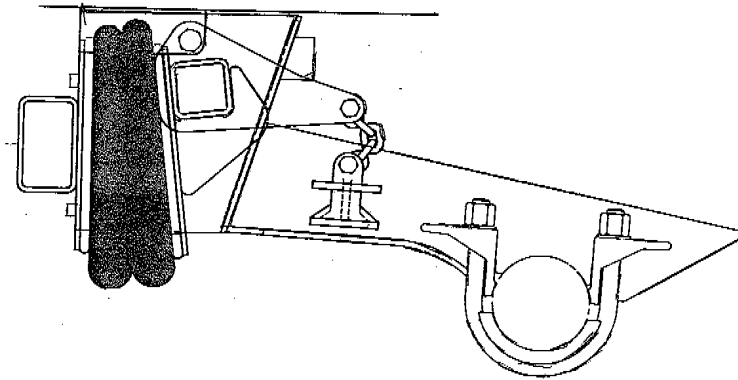

### Description

As part of our continuous product improvement program, Hendrickson have updated our recommended air system plumbing on CL-100, CL-101 and CL-102 Centre Lift Kits fitted to HT230 Trailer Suspensions

The system recommendations now require a 550kPa (80psi) pressure regulator fitted in line to limit pressure to the 'lift' air spring.

A 98732-006 Pressure Regulator is available from Hendrickson and is now included in CL-100, CL-101 and CL-102 Centre Lift Kits as part of the bill of materials.

As such, the kits will now have a revised part number to reflect the inclusion of the regulator valve.

The new part numbers for these kits are CL-100A, CL-101A and CL102A.

This bulletin contains product improvement information only. Hendrickson is not committed or liable for canvassing existing product.

For further assistance, contact the Hendrickson Customer Excellence Centre on (03) 9767-3400.

**WARNING - HENDRICKSON REMINDS USERS TO ADHERE TO THE PUBLISHED CAPACITY RATINGS FOR SUSPENSIONS. DO NOT MODIFY PARTS OTHER THAN OUTLINED IN THIS PUBLICATION.**

**USE OF A MODIFIED OR SUBSTITUTE PART IS NOT RECOMMENDED BECAUSE THE PART MAY NOT MEET HENDRICKSON'S SPECIFICATIONS, WHICH COULD LEAD TO FAILURE OF THE PART, LOSS OF VEHICLE CONTROL AND PERSONAL INJURY.**