

SUPERIOR COMFORT

OUTSTANDING RIDE

IMPROVED HANDLING

REDUCED MAINTENANCE

H **COMFORT AIR™**

Single Axle Air Suspension

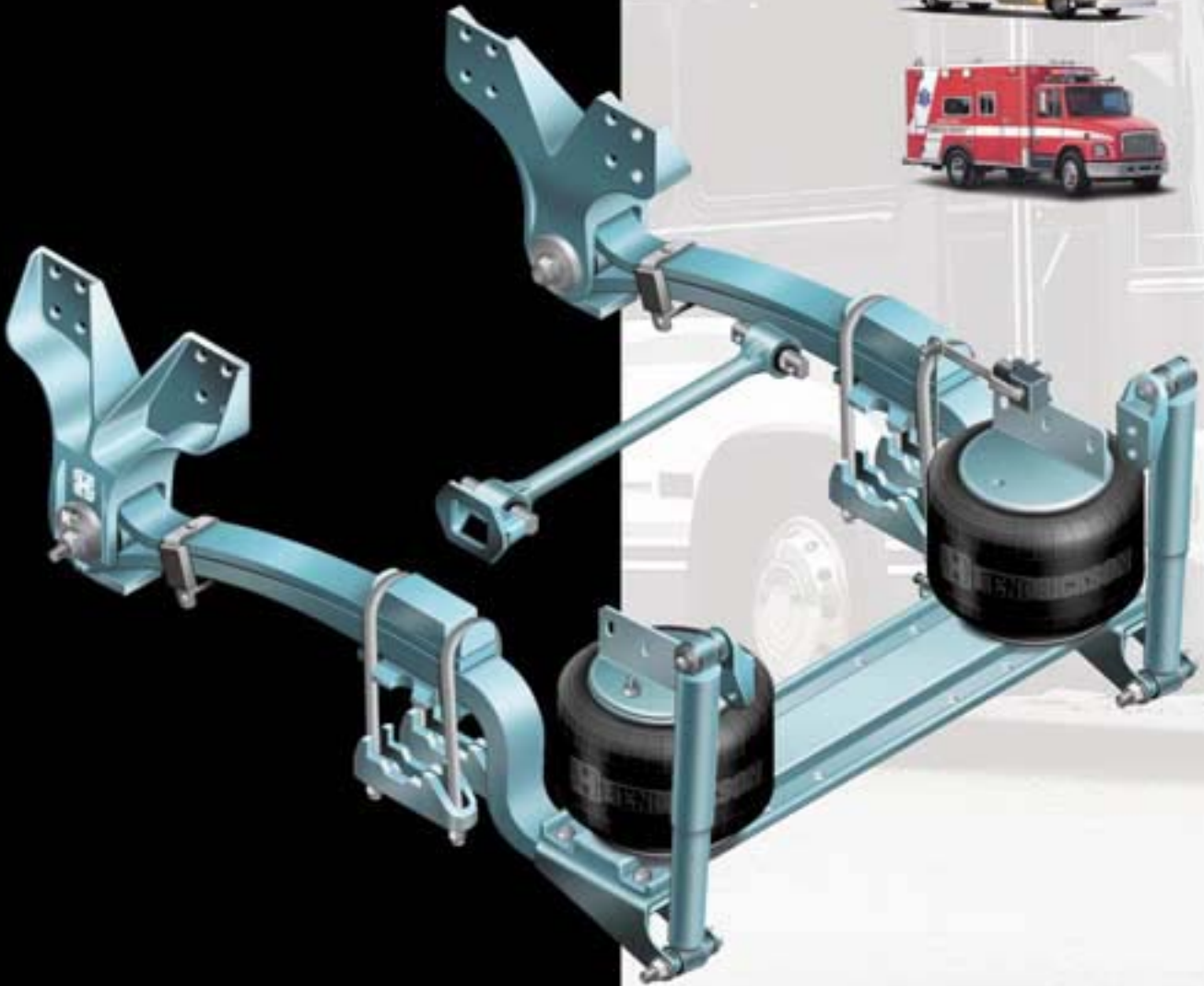

For The Road Ahead™

H **HENDRICKSON**

COMFORT AIR™ — designed with the passenger and driver in mind. If you're running buses, ambulances or motor homes, you're transporting precious cargo — people.

SUPERIOR RIDE AND HANDLING WITH ENHANCED EQUIPMENT PROTECTION.

Drawing on a 75-year legacy of innovation, superior design, and quality manufacturing, Hendrickson responded to the customers' requirements with an engineered ride solution. The design is based on our proven HAS trailing arm and axle connection technology, with the primary focus on the customer, passenger and driver needs.

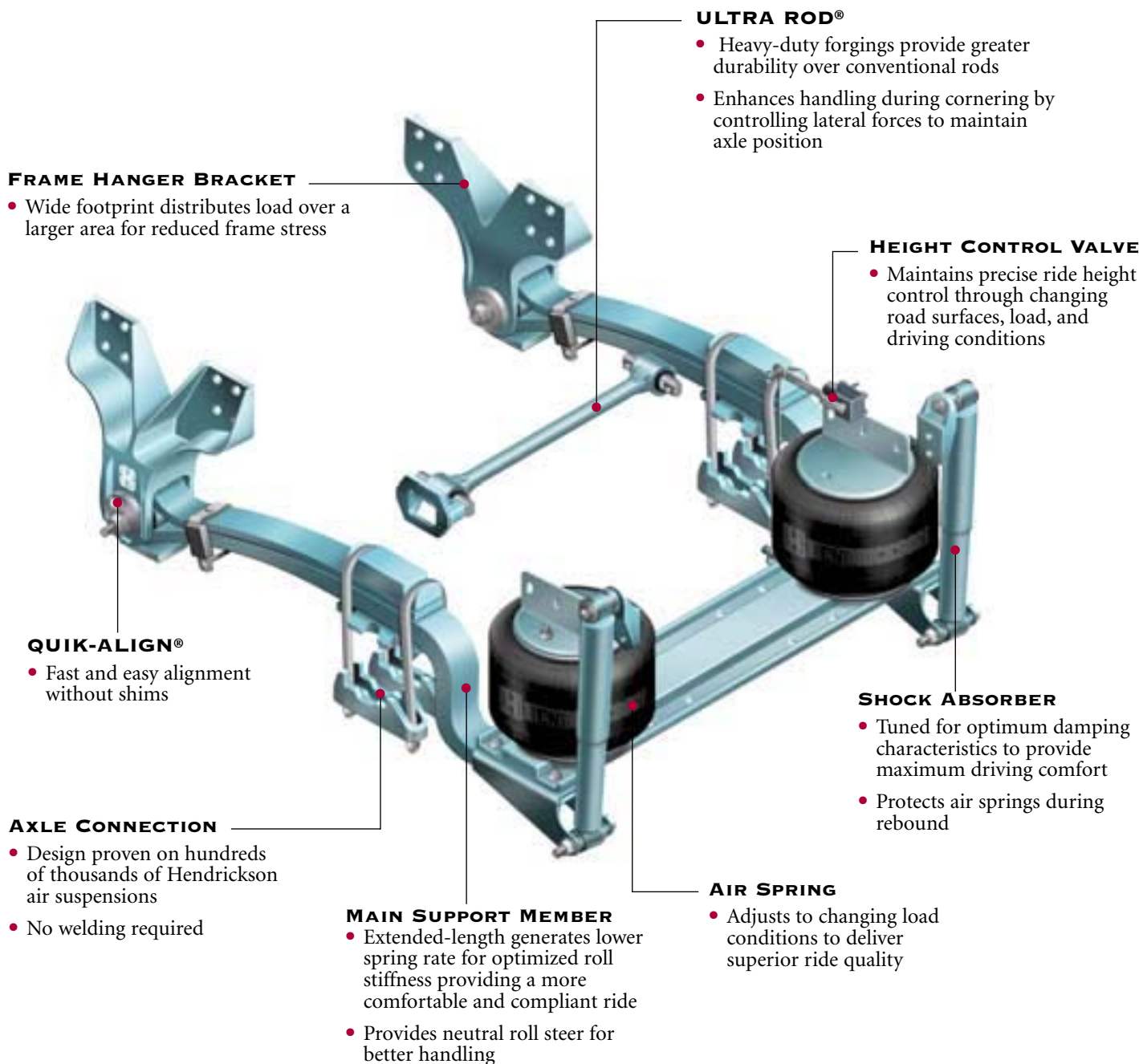

FOCLIS

VEHICLE PROTECTION AND REDUCED MAINTENANCE

COMFORT AIR™ helps protect your equipment from bumps and potholes in the road. The wider frame hanger bracket spreads out forces over a greater area, reducing stress to the frame to help increase the life of the vehicle.



Durable pivot bushing connection provides quiet operation and helps extend suspension service life.

Hendrickson's proven QUIK-ALIGN® axle alignment feature reduces maintenance time. QUIK-ALIGN offers a fast method to adjust and set alignment by using two flanged collars that are inserted into slots on each side of the frame hanger bracket. The outboard driver's side flanged collar is eccentric with a 1/2-inch square opening to insert a breaker bar or ratchet.



Maximum range of adjustment is ± 90 degrees from 12 o'clock positioning.

By rotating the eccentric collar clockwise or counter-clockwise, the suspension's axle is moved fore or aft $\pm 1/2$ inch.



FOCLIS

PASSENGER AND DRIVER COMFORT

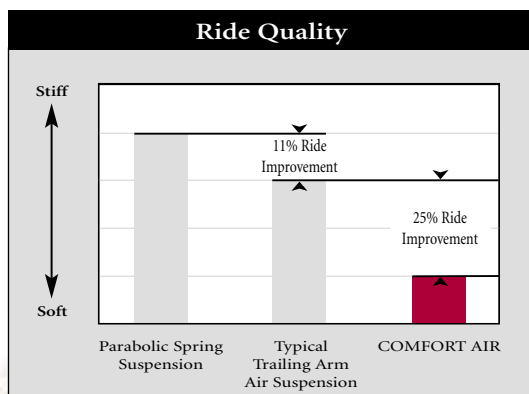

Using advanced spring technology from Hendrickson, COMFORT AIR's main support member has an elongated design for optimized roll stiffness. This provides a softer ride and greater protection from the effects of road shock on your chassis, equipment, drivers, and passengers.

A longer main support member allows the air springs to carry more of the vertical load to provide a softer ride.

The axle center is on a horizontal line with the pivot point, generating neutral roll steer characteristics for improved handling quality while cornering.

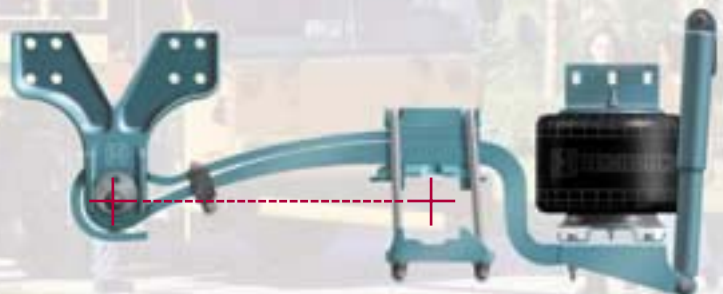

COMFORT AIR™ SPECIFICATIONS

Suspension Rating^{1,2}	15,000 lbs. — 23,000 lbs.
Suspension Weight³	487 lbs.
GVW	40,000 lbs.
Ride Heights	8.5" — 10.5" (with straight frames)

COMFORT AIR is approved for most bus applications. Contact Hendrickson for application approval.

¹ COMFORT AIR is approved for up to 10% off-highway use.

² All rear engine vehicles require a minimum 4.5 degree pinion angle.

³ Suspension weight includes complete suspension and transverse torque rod. Weight may vary slightly based upon application specific configuration.



HENDRICKSON
Genuine Parts

Hendrickson Genuine Parts are the same quality components installed in Hendrickson original equipment suspensions — consisting of the same design, construction, performance and durability. There's only one way to maintain and protect your suspension's original performance. Ask for the name that is synonymous with the finest manufactured suspensions in the world — Hendrickson.

Information contained in this literature was accurate at the time of publication. Product changes may have been made after the copyright date that are not reflected.

Visit us at www.hendrickson-intl.com

HENDRICKSON