

# TECHNICAL BULLETIN

## INTRAAAX AA250 TRAILER AIR SUSPENSION AXLE RESTRAINING SYSTEM

**No:** TRAILER AUS-010  
**Subject:** Improvement  
**Date:** August 1998 **Revision:** A

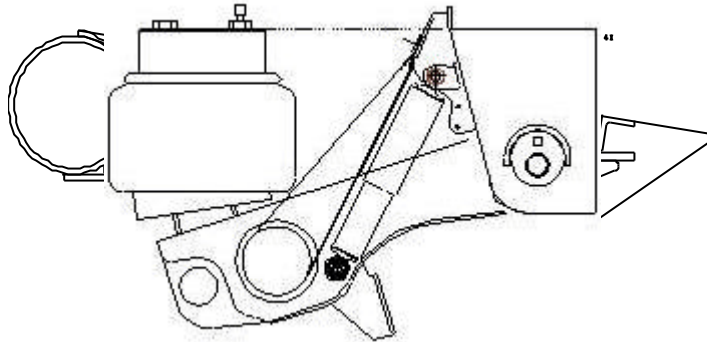

As part of our continuous product improvement program, Hendrickson has released a repair procedure to allow field units to be serviced effectively.

*As part of our continuous improvement program, Hendrickson have released an Intraax AA250 axle restraining system (98918-002) to alleviate isolated reported concerns. Also refer bulletin AUS-007*

Part number 98918-002 consists of;  
2 x Brackets      2 x Restraint Straps  
2 x Bolts          2 x Lock nuts  
4 x Washers      1 x Instructions

*If the suspension operation is such that the axle is lifted off the ground in a tip-over axle application, Hendrickson recommend the restraint kit be installed.*

*Installation instructions included in the kit are comprehensive and must be adhered to for optimum performance.*

*The restraining system is also available as an option on all Intraax suspensions.*

**WARNING:**  
**HENDRICKSON REMINDS USERS TO ADHERE TO THE PUBLISHED CAPACITY RATINGS FOR SUSPENSIONS.**

**DO NOT MODIFY PARTS OTHER THAN AS OUTLINED IN THIS PUBLICATION.**

**USE OF A MODIFIED OR SUBSTITUTE PART IS NOT RECOMMENDED BECAUSE THE PART MAY NOT MEET HENDRICKSON'S SPECIFICATIONS, WHICH COULD LEAD TO FAILURE OF THE PART, LOSS OF VEHICLE CONTROL AND POSSIBLE PERSONAL INJURY OR DAMAGE OF PROPERTY.**

*If any further installation detail or assistance is required, contact the Hendrickson Customer Service Department on (03) 9767 3400*

*This bulletin contains product improvement information only. Hendrickson is not committed or liable for canvassing existing product*

 HENDRICKSON

ABN 21 004 992 769

5 Abbotts Road, P.O. Box 1063, Dandenong, Victoria 3175 Australia  
Phone 61.3.9767.3400 Fax 61.3.9767.3499

[www.hendrickson.com.au](http://www.hendrickson.com.au)